



go.

Owners Manual

Notice



This owner's manual contains important safety, operational and maintenance information. Any person operating or riding as a passenger on your scooter should carefully read and fully understand the entire contents of this manual prior to riding the vehicle. For your safety, follow all safety warnings contained within the owner's manual and the labels applied to your scooter. You should keep this owner's manual in your vehicle at all times and it should be considered a permanent part of the vehicle.

If you have any questions, please ask your dealer for assistance.

Safety symbols and notes. Please observe the following:



WARNING

Failure to follow instructions with a WARNING symbol could result in serious injury or death. Precautionary measures are required.



CAUTION

Important instructions and precautionary rules to avoid damage to the vehicle. Non-observance can lead to an unsafe vehicle condition.



NOTE

Special instructions and precautionary measures for better handling during operation, inspection, adjustment and service activities.



WARNING

California Proposition 65

Operating, servicing and maintaining a passenger vehicle or off-road vehicle can expose you to chemicals including engine exhaust, carbon monoxide, phthalates, and lead, which are known to the State of California to cause cancer and birth defects or other reproductive harm. To minimize exposure, avoid breathing exhaust, do not idle the engine except as necessary, service your vehicle in a well-ventilated area and wear gloves or wash your hands frequently when servicing your vehicle. For more information go to www.P65Warnings.ca.gov/passenger-vehicle.

Introduction



Congratulations on your purchase of the Chicago Scooter Company go./go. Max

Please read this manual carefully prior to riding so that you will understand how to safely operate your scooter, understand its capabilities and limitations and become aware of all vehicle controls and features.

This owner's manual contains important maintenance information. The efficiency and longevity of your scooter will depend heavily on your operating methods and periodic maintenance. Failure to operate and maintain your scooter as instructed in this owner's manual may void the limited warranty and reduce the efficiency and reliability of your vehicle.

The first 500 miles are the most important in the life of your scooter. Proper break-in during this time will ensure maximum life. Please refer to the break-in section for specific break-in procedures prior to riding.

You should always use original Chicago Scooter Company OEM parts for all maintenance and repairs as they have been designed specifically for your vehicle.

Genuine Motor Oil is the official lubricant of Chicago Scooter Company vehicles. Genuine Motor Oils have been formulated to specifically keep your engine running efficient with minimal engine wear.

Your authorized Chicago Scooter Company dealer is the primary resource for information, parts and service. If you have any questions, please ask your dealer for assistance.

Table of Contents



NOTICE	1
INTRODUCTION	2
TABLE OF CONTENTS	3
VEHICLE SAFETY	
Accessories, Modification, Noise Regulation.....	4
Loading, Maintenance, Pre-ride Inspection	5
Carbon Monoxide Gas.....	5
SAFE RIDING	
Wear Safety Gear, Make Yourself Visible.....	6
Know Your Limits, Road Conditions.....	6
IDENTIFICATION NUMBERS	7
VEHICLE LAYOUT	
USB Charging, Ignition Switch.....	8
Dashboard.....	9
Handlebar Controls.....	10
Front and Rear Brake Controls.....	11
Kick Start, Seat Lock.....	12
Storage, Bag Hook.....	13
Fuel Fill.....	14
PRE-RIDE INSPECTION	
Pre-ride Inspection Checklist.....	15
Front Brake Inspection and Adjustment.....	16
Rear Brake Inspection and Adjustment.....	17

PRE-RIDE INSPECTION (CONTINUED)	
Throttle Inspection and Adjustment.....	18
Engine Oil Type, Level Check, and Fill	19
Tire Inspection and Pressure Adjustment.....	20
Cable Inspection and Lubrication.....	21
Vehicle Center and Side Stand, Assembly Check.....	21
Fuel, Lighting, Switches, and Loading.....	22
OPERATION	
Engine Starting	23
Engine Run-in, Engine Life.....	24
Engine Warm-up, Riding, Throttle.....	25
Braking.....	26
Engine Stop, Parking.....	27
PERIODIC MAINTENANCE	
Periodic Maintenance Key.....	28
Periodic Maintenance Table.....	29
Periodic Maintenance Table Continued.....	30
Air Cleaner, Gear Oil, Transmission.....	31
Spark Plug, Front Brake.....	32
Brake Fluid, Suspension.....	33
Fuses, Battery.....	34
Maintenance Record.....	35
TECHNICAL DATA	36
REPORTING SAFETY DEFECTS	37

Vehicle Safety



Accessories

The addition of unsuitable accessories can result in unsafe operating conditions.

Chicago Scooter Company approved accessories have been designed for and approved by CSC for use on your scooter. Always install CSC approved accessories on your scooter. Your dealer can assist you in selecting and correctly installing accessories for your scooter.



Modification

Modification of your scooter or removal of original equipment may render the vehicle unsafe or illegal. Obey all applicable equipment laws and regulations. Only use accessories that have been approved by Chicago Scooter Company for this scooter.

Motorcycle Noise Regulation

TAMPERING WITH NOISE CONTROL SYSTEM PROHIBITED

Federal law prohibits the following acts or the causing thereof: (1) The removal or rendering inoperative by any person other than for purposes of maintenance, repair, or replacement of any device or element of design incorporated into any new vehicle for the purpose of noise control prior to its sale or delivery to the ultimate purchaser or while it is in use or (2) the use of the vehicle after such device or element of design has been removed or rendered inoperative by any person.

"AMONG THOSE ACTS PRESUMED TO CONSTITUTE TAMPERING ARE THE ACTS LISTED BELOW".

These acts include tampering with the following systems; i.e., modification, removal, etc.

Exhaust System - Muffler, Exhaust pipe, Silencer Intake System - Air cleaner case, Air filter, Intake duct

Vehicle Safety

**CHICAGO
SCOOTER CO.**

Properly load your scooter

You and any passengers should utilize the floorboard and footrests for your feet. Do not exceed the load limits of the vehicle. Properly secure all cargo.



Maintain your vehicle

Perform any maintenance required per the maintenance schedule or as otherwise necessary to keep your scooter in a safe operating condition. If you notice any leaks or notice odd sensations such as vibration, immediately stop your vehicle.

Pre-Ride Inspection

Always perform a pre-ride inspection of your scooter prior to each ride. Review the pre-ride inspection instruction section contained within this manual for more information.

WARNING

Not performing a pre-ride inspection, altering your vehicle from the stock configuration, or failure to properly maintain your vehicle can result in serious injury or death. Check your vehicle regularly and have any problems corrected as soon as possible.

Carbon Monoxide Gas

The exhaust gasses from this vehicle contain carbon monoxide, a colorless, odorless, and highly toxic gas.

An enclosed area such as a garage can quickly fill up with carbon monoxide gas. Do not run the engine in enclosed areas that are poorly ventilated. Move the vehicle outdoors before operation.



WARNING

Carbon monoxide gas is toxic. Breathing carbon monoxide can cause unconsciousness and even kill you. Avoid running your engine within enclosed areas and other activities that expose you to carbon monoxide.

Safe Riding

CHICAGO
SCOOTER CO.

Your scooter can provide many years of riding enjoyment. You must take responsibility for your own safety and the safety of others. There are many steps you can take to protect yourself and others while riding. Here are some very important safety precautions:

Wear a helmet

Rider safety begins with quality head protection. A head injury is one of the most serious injuries that can occur. Always wear a quality DOT approved helmet that is properly buckled. If the helmet does not have a face shield, wear suitable eye protection.

Wear riding apparel

Choose quality gloves, boots, pants, jackets and other riding apparel specifically designed with protective features. Loose clothing can be unsafe when riding your scooter.

Make yourself visible

Wear bright, reflective apparel to make yourself more visible to fellow drivers. Position yourself on the road where other drivers can easily see you. Use your turn signals, hand signs, horn and other methods to help others locate you and understand your driving actions.

⚠️ WARNING

Not wearing safety apparel increases the chance of serious injury or death in a crash. Be sure you and your passengers always wear helmets and protective gear and wear them properly.



Know your limits

Ride within the boundaries of your own skill at all times. Do not ride under the influence of drugs or alcohol. Strictly observe all traffic regulations. Always adapt your riding to account for traffic and road conditions.

Road conditions

Road conditions can vary greatly with weather, foreign material, elevation etc. Your riding stability and braking power are limited by the grip of the tires on the road surface. When encountering slippery road surfaces, braking distance will increase significantly and riding stability will be reduced. Reduce vehicle speed and perform all actions in a gradual and deliberate manner to prevent accidents. Use extreme caution on painted surfaces or metal objects such as a manhole cover or train rails when they are wet.

Identification Numbers



Vehicle Identification Number (VIN) is located on the VIN plate (1) or inside the inner front cover (2).

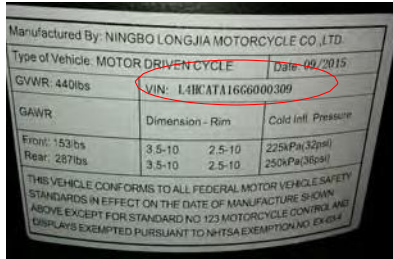

Record your Vehicle Identification Number: _____



Engine Serial Number (3) is located on the back of the engine.

Record your Engine Serial Number: _

Ignition Switch

Insert the key and select "ON" (1), "OFF" (2), or "LOCK" (3)

Turn key to "ON" position to operate the vehicle. In this position, the key cannot be removed. The vehicle will have power and the engine can be started.

Turn key to "OFF" position to cease vehicle operation. In this position, all vehicle power will be off, the engine will not run, and the key can be removed from the ignition switch.

Turn handlebars fully to the left steering-stop, then push and turn key to "LOCK" position to lock the handlebars as a theft deterrent. The fork is now locked and cannot be turned

It is suggested you "LOCK" your vehicle whenever you leave the vehicle unattended. The key can be removed from the ignition switch in this position.



Vehicle Layout



Dashboard

1. Directional Indicator - Light will illuminate green when turn signal button is pressed to the left or right.
2. High Beam Indicator - Light will illuminate blue when high beam switch is pressed upward.
3. Fuel Level Indicator - Gauge will show approximate fuel level in fuel tank. Gauge will move from "F" to "E" as fuel tank depletes. When key is off, gauge will show "E".
4. Speedometer - Gauge will show current speed.
5. Odometer - This will show distance traveled during the life of the vehicle.

go.



go.
Max



Handlebar Controls

1. Headlight

Select  for HIGH Beam

Select  for LOW Beam

2. Turn Signal

Press  to signal a LEFT turn.

Press  to signal a RIGHT turn.

Press middle to turn signal indicator OFF.

3. Horn Button

Press  to sound the HORN.

4. Engine Kill Switch

Leave this button in the  RUN position at all times unless there is an emergency situation.

In an emergency, press  to STOP engine!

5. Starter Button

Press  with the key ON to START the engine.

Left Handlebar Controls

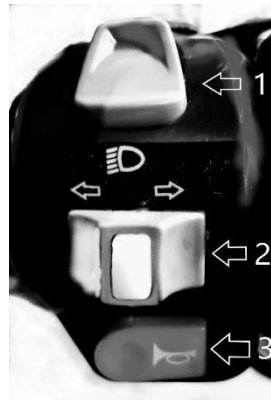

Right Handlebar Controls

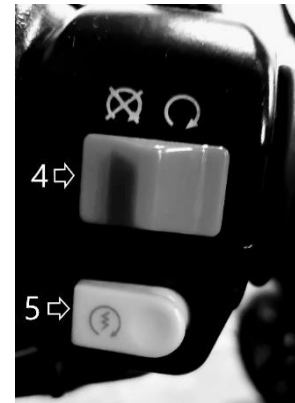

Vehicle Layout

CHICAGO
SCOOTER CO.

Front & Rear Brake Controls

- Extend your fingers over the brake lever.
- Pull lever toward the grip to actuate brake.
- The brake lever should slow the vehicle with firm pressure.

REAR BRAKE LEVER



FRONT BRAKE LEVER



WARNING

The brake lever should not touch the handlebar. If the brake lever feels soft or touches the handlebar, have your brake system inspected and adjusted or repaired immediately.

Vehicle Layout



Kick Start

The kick-start lever can be used to start your engine as an alternative to the electric-start option.

Pull the kick-start foot peg with rubber sleeve outward, away from the engine cover (1).

While facing forward and holding both handlebar grips, press down quickly with your foot to start the engine (2).

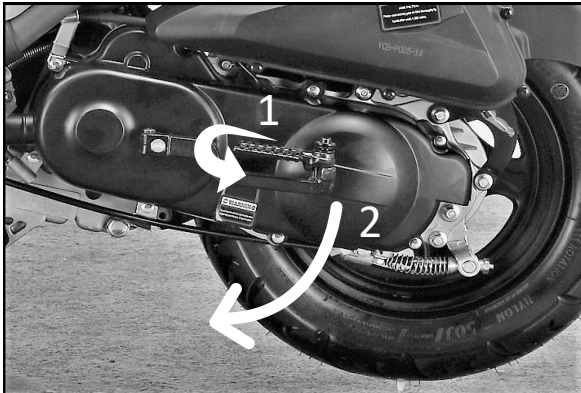

Seat Lock

To access the under-seat storage area, insert key into the lock and turn the key. The seat will release from its latch. Raise the seat forward toward the handlebar to expose the storage area.

Return the seat to rest on the latch and press downward on the seat to securely close it. (2)

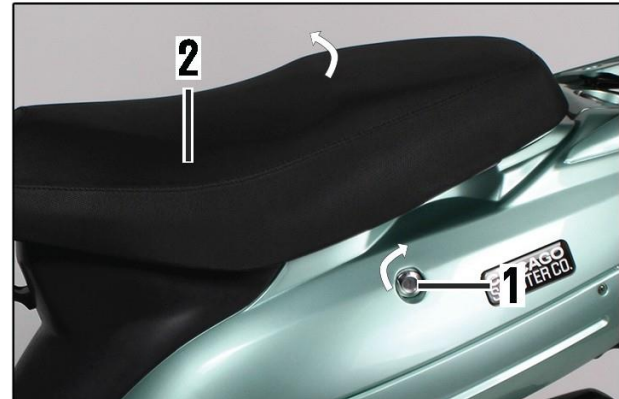

Vehicle Layout



Storage

Storage is located under the seat.

1. The maximum loading capacity is 5 lbs.
2. The under-seat storage compartment can become very hot when the ambient temperature is high and the engine has been operating for a long period. Do not put perishable or temperature-sensitive items in the luggage compartment.
3. The storage compartment is not waterproof. When it rains or after washing your vehicle, the storage compartment may get wet with moisture. Do not store water-sensitive items in the storage compartment.



Bag Hook

A bag hook is located on the inner front side of the leg shield. Ensure all bags and other cargo are properly secured to prevent spillage and subsequently a potential hazard for other motorists.



Vehicle Layout



Fuel Fill

The fuel cap is located behind the seat.

Fill with premium unleaded fuel 87 octane or higher.

Take special care not to overfill fuel tank.



Unlock

- Flip the tank cap cover to the upright position.
- Insert the ignition key into the lock (2)
- Turn the upright cover counter-clockwise to open the tank cap. There is no need to turn the key once it is inserted into the cap.

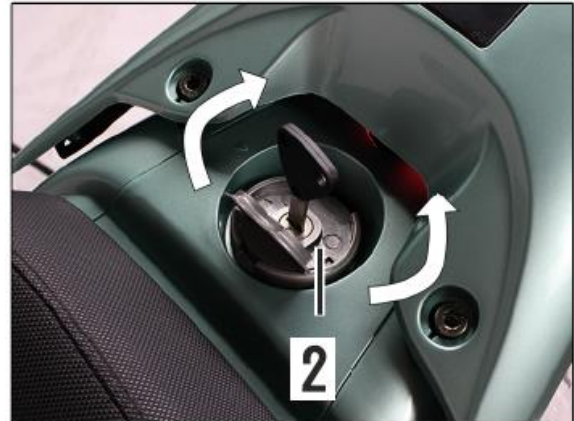

Pre-Ride Inspection



Perform a pre-ride inspection prior to every ride. This is a checklist. Detailed procedures are given in the pages that follow.

ITEM	PROCEDURE
FRONT BRAKE	Check the brake function, clearance, brake-fluid level, inspect for fluid leaks, if necessary, add DOT 4 or higher brake fluid. Check brake lever free-play and adjust if necessary. Check brake pad wear. If the brake pads are worn down past the wear marks, replace pads immediately.
REAR BRAKE	Check the brake function, lever free-play and clearance. Make adjustments and lubricate cable if necessary. If the brake shoes are worn, replace immediately.
THROTTLE	Check to make sure the throttle actuates freely through the range. Lubricate throttle cable if necessary. Check throttle free-play. Adjust throttle cable tension if necessary.
LUBRICANTS	Check the engine oil level before each ride. If the engine oil level is low, refill with JASO MB 15W-40 engine oil
TIRES	Check tire pressure in both the front and rear tire, add air if necessary. Inspect tires.
CABLES	Check operation of all cables. Lubricate cables and adjust tension as necessary.
CENTER/SIDE STAND	Check center and side stands for operation, lubrication and secure mounting.
ASSEMBLY	Check all vehicle assembly to ensure fasteners are secure and assemblies function properly.
FUEL SYSTEM	Check fuel level. Fill if necessary. Ensure no fuel leaks are present.
LIGHTING	Check the function of all lights. Clean lenses as necessary.
SWITCHES	Check the function of all switches.
LOADING	Ensure your vehicle is not overloaded, is loaded in a balanced manner, and cargo is secured.

Pre-Ride Inspection



Perform a pre-ride inspection prior to every ride.

Front Brake

The front brake is a hydraulic disk type. Inspect the brake system prior to each ride. Properly functioning brake systems are vitally important to your personal safety.

Check for fluid leaks, fluid level, brake pad wear, and rotor condition. Also check lever free-play frequently.

Pull the brake lever lightly until you feel tension, then check the lever free-play.

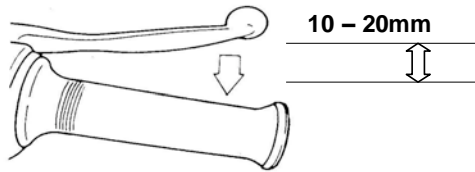

Front Brake lever free-play : 10-20mm

If the brake lever has no free-play or is too loose, there is a potential brake system fault. Inspect brake system thoroughly.

Front Brake Fluid

Check all joints along the brake hose for any brake fluid leaking from the joint or the brake cylinder. Leakage has occurred if you see wet or oxidized fluid sludge. Check brake fluid port to see brake fluid level; add brake fluid if necessary.

Brake fluid specification: DOT4



WARNING

A brake lever that is not firm when engaged implies there is a problem with the brake system. Do not drive your vehicle until the problem has been resolved. Bring the vehicle to your authorized Chicago Scooter Company dealer for repair.

WARNING

Contact your Chicago Scooter Company dealer immediately to repair any brake fluid leaks. A leak could result in loss of hydraulic pressure to your brake system rendering the front brake useless.

Pre-Ride Inspection

CHICAGO
SCOOTER CO.

Perform a pre-ride inspection prior to every ride.

Front Brake Disc

Inspect the brake disc for wear. Inspect the brake pads to ensure the pad thickness is not beyond the wear limit. If the brake pad wears entirely before replacement, damage to the disc and loss of braking ability can occur.



Rear Brake

The rear brake is a cable-actuated drum brake system. Inspect the brake system prior to each ride. Properly functioning brake systems are vitally important to your personal safety.

Check rear brake cable condition and brake wear.
Check lever free-play and adjust as necessary.

Rear Brake Free-Play

Pull the brake lever lightly until you feel tension, then check the lever free-play.

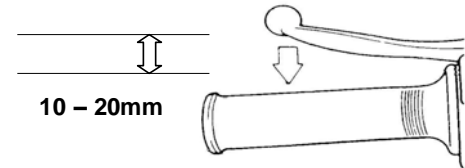

If lever free-play is too large or too little, adjust free-play by turning the adjustment nut on the cable near the rear wheel.



Check cable and pivot for lubricant. Lubricate regularly to ensure cable moves easily, without binding.

Pre-Ride Inspection

CHICAGO
SCOOTER CO.

Perform a pre-ride inspection prior to every ride.

Rear Brake Wear

There is a wear indicator installed on the brake actuator shaft. When the indicator (3) lines up with the mark on the engine case (4), your brake shoes have worn beyond the usable range and should be replaced.

Failure to replace the brake shoes can result in damage to the hub and a loss of braking ability.

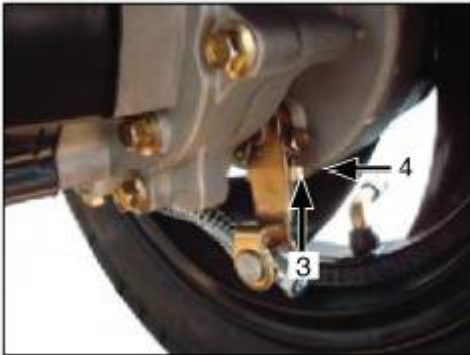

Throttle

Check the throttle cable for ease of movement by turning the twist grip from fully closed to fully open.

Move the handlebar left to right to ensure throttle is not applied when bars turn.

Measure throttle free-play by opening the grip slightly until resistance can be felt. **Throttle free-play: 1.5-3.5 mm**

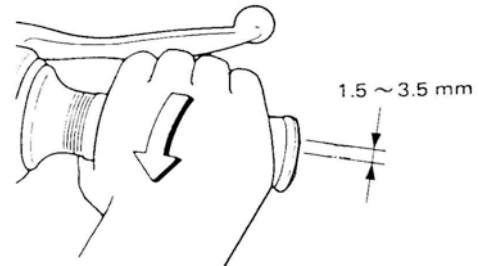

Adjust throttle as necessary to ensure proper free-play. Lubricate throttle cable tube and cable ends to ensure ease of operation.

⚠ WARNING

An improperly adjusted throttle, non-lubricated or binding throttle cable is an extremely dangerous condition that can result in loss of control of your vehicle. Maintain and inspect frequently.

Pre-Ride Inspection

CHICAGO
SCOOTER CO.

Perform a pre-ride inspection prior to every ride.

Engine Oil

Genuine Motor Oil is the oil brand recommended by Genuine Scooters. Your scooter operates under intense conditions, including higher engine speed, hotter temperatures, and higher compression ratios than other vehicle types. These conditions subject the oil to significant operational stress and require a lubricant specifically designed for scooters.

Only use JASO MB 15W-40 engine oil in your engine.

JASO MB oils are very low friction oils formulated for use in engines that do not have wet clutch systems. Other oil types may severely damage your engine and void any warranty. All JASO rated oils will display the JASO oil classification on the bottle within an outlined border.



Many oils claim to “meet or exceed” JASO ratings but are not officially certified by JALOS. If an oil does not have a 10-character oil code and the JASO MB rating prominently displayed on the label then the oil is not certified by JALOS and should not be used in your scooter.

Engine Oil Check

The engine oil fill access is located near the lower right side of the vehicle. Remove the cap and check the oil level on the dipstick.

Add JASO MB 15W-40 engine oil if the oil level is low. Replace cap.

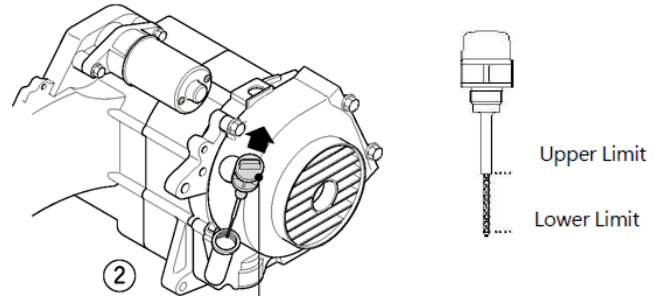

Check oil level prior to each ride. Fill as necessary.

⚠ WARNING

Failure to use JASO MB 15W-40 oil and/or failure to maintain proper oil level in your engine may result in premature wear, severe engine damage or catastrophic engine failure.

Pre-Ride Inspection



Perform a pre-ride inspection prior to every ride.

Tires

Perform a physical inspection of both the front and rear tire. Inspect the tread depth to gauge tire wear.

Locate the initials T.W.I. on the tire sidewall. This is the location of the Tread Wear Indicator. Move inward toward the center of the tire to find the raised portion of the tire groove. This is the Tread Wear Indicator. Replace tire when tread wear indicators come in contact with the road surface.

Inspect the tire for foreign material such as nails, screws, glass or other objects that may have become lodged in the tire. Visit a Chicago Scooter Company dealer for tire replacement if necessary.

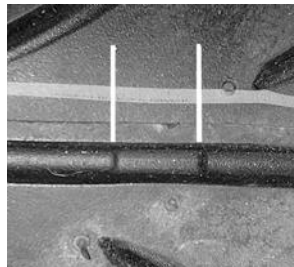

Tire Pressure

Perform tire pressure checks while the tires are cold:

- Remove the valve caps.
- Check the tire pressure.

Standard Tire Pressure

Front: 32 psi

Rear: 36 psi

- Adjust the tire pressure according to the total weight load.
- Re-install the valve caps.



WARNING

Never exceed the rated total weight or the bearing capacity of the tires. Incorrect tire pressure will have a considerable effect on the riding properties of the scooter and can cause an accident.



Pre-Ride Inspection



Perform a pre-ride inspection prior to every ride.

Cables

Check all cables for integrity, connection and lubrication. If any fraying or other cable damage is observed, replace cable immediately.

Use a cable specific lubricant on the braided portion of the cable.

Use waterproof grease on the cable ends and pivot locations.

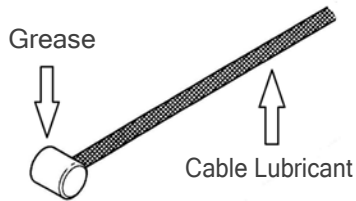

Center Stand and Side Stand

Inspect both the center stand and the side stand to ensure the mounting bolts securely fasten the stands to the frame and both stands are not loose.

Check spring tension to ensure stands will remain in stowed position when riding.

Assembly

Check all assemblies to ensure they are fastened tightly. This includes both a visual and physical inspection.

Visually inspect the engine, fork assembly, wheel assemblies, handlebar, and other critical components. Apply pressure in all directions for each assembly to check for unusual movement. If you notice any unusual vibration, shake or other indication that a problem may exist, have your vehicle towed to a Chicago Scooter Company dealer for inspection and resolution.

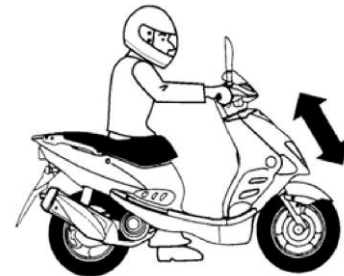

FUNCTION CHECK

Pre-Ride Inspection



Perform a pre-ride inspection prior to every ride.

Fuel System

Check your fuel level prior to each ride.

Fuel Tank capacity: 5 liters

Fuel specification: Unleaded 87 octane or higher

Do not fill your fuel tank over the neck-line on the fuel tank inlet.

Fuel expands under the influence of heat. An over-filled fuel tank can cause fuel to spill when the vehicle is warm.

Inspect your fuel system including tank, hoses, petcock and filter for leaks. If a leak is found, repair immediately.



WARNING

Both fuel and fuel vapor are highly flammable. Do not smoke or bring an open flame near the fuel tank. Explosions can occur.

Lighting

Lighting is a very important safety feature that helps you navigate at night and communicate your actions with other drivers.

Properly functioning lighting can make you more visible to other drivers, reducing the possibility of an accident.

Check the front and rear turn signal indicators, head light, tail-light, brake light, speedometer backlighting, and all indicator lights to assure they are in proper working order. Make sure all lenses are clean of dirt and debris.

Switches

Check the function of all switches for lighting, signals, horn, etc. Repair as necessary.

Loading

Load your scooter properly. An improperly loaded scooter can cause an accident.

- Make sure the left-to-right weight distribution is balanced.
- Check that all fasteners are correct and tight.
- Do not transport bulky loads.
- Do not load your vehicle in a manner that covers lighting or impedes the movement of any vehicle component.

Vehicle Operation

Before starting your vehicle, you should be familiar with all operations and functions of this vehicle. You should have completed the pre-ride inspection, and you should be wearing safety gear.

If this is the first time you are operating your vehicle, you should thoroughly review the "Initial Engine Run-In" section on the next page.

Vehicle Start using Electric-Start Method

- 1) Ensure the kill switch is in the RUN position.
- 2) Insert the key into the Ignition Switch and turn to ON.
- 3) With the throttle completely closed, pull in either brake lever & simultaneously push and hold the start button. Once the engine starts, release the start button.

Do not press and hold the start button for more than 5 seconds at a time as this can damage the start system. If the vehicle has difficulty starting after pressing the start button for 5 seconds, release the start button. Wait 10 seconds between attempts. Try to start the vehicle again for up to 5 seconds at a time.

If your vehicle does not start after several attempts, start your vehicle using the kick start method.

Vehicle Start using Kick-Start Method

- 1) Place vehicle on the center stand.
- 2) Ensure the kill switch is in the RUN position.
- 3) Insert the key into the ignition and turn to ON position.
- 4) Open the kick-start lever footpeg.
- 5) Grasp both handlebar grips firmly, place your foot on the kick-start lever footpeg, and kick downward in a rapid motion.
- 6) Kick repeatedly until engine starts.
- 7) After starting, return kick-start lever footpeg to normal position.



NOTE

It is not necessary to hold the brake lever in when starting your vehicle with the kick-start method.

If your vehicle does not start after trying both the electric and kickstart methods, you should contact your Chicago Scooter Company dealer for assistance.

Operation



Initial Engine Run-In

When your engine is new or when you have installed new engine components, it is very important to follow this run-in procedure. During this period of operation, each part within the engine will obtain proper operating tolerances. Following the run-in procedure will maximize the life of your engine.



CAUTION

During the first 500 miles of operation, avoid wide-open throttle operation or any operation that may cause high engine temperatures.

0 - 100 miles

Avoid opening the throttle beyond 1/2 throttle. Cool down the engine for 10 minutes, after every 30 minutes of operation. Do not operate at a constant speed; change your speed regularly.

100 - 300 miles

Avoid opening the throttle beyond 1/2 throttle for extended periods of time. Do not open throttle beyond 3/4 throttle.

300 - 500 miles

Avoid opening the throttle beyond 3/4 throttle.

Over 500 miles

Avoid long periods of wide-open throttle operation.

Engine Life

Your engine life is highly dependent upon how you operate and maintain your vehicle.

Your scooter is equipped with a CVT transmission and your engine will operate at maximum RPM when you are at maximum speed at wide-open throttle.

If you operate your scooter at maximum RPM for a long period, you will damage your engine. This is not considered normal operation.

Keep your maximum speed operation to short periods of time. If you are travelling a longer distance, slow or stop your vehicle regularly to allow the engine to cool.

The quality of oil that you use in your vehicle will also determine longevity. Please reference the Engine Oil section in this manual for the proper specification.



CAUTION

Operating your vehicle at wide-open throttle for any long duration generates excessive heat that can damage your engine. Be aware of the length of full throttle operation and slow down periodically to allow the engine to cool especially in hot climates. Always use quality engine oil in your vehicle.

Engine Warm-Up

After engine start, allow the engine to come up to operating temperature by idling the engine for at least 1 minute and then using mild acceleration during the first 3 minutes of operation.

While the engine is warming up, sit on the scooter and adjust the rear view mirrors to be able to see clearly behind you from both the right and left sides.

Riding

After engine warm up, you are ready to ride. Be sure you have completed the pre-ride checklist before each ride.

Use the throttle for controlling the general speed of your vehicle.

Use the brakes for slowing and stopping your vehicle.
Use the handlebars to control the direction of the vehicle.

Rider inputs will determine the behavior of the vehicle. Make sure you take into account the weather, riding surface, traffic and all other circumstances that may alter the amount of time it will take to accelerate, stop and turn your vehicle.

Hold the rear brake lever and push the vehicle forward off the center stand.

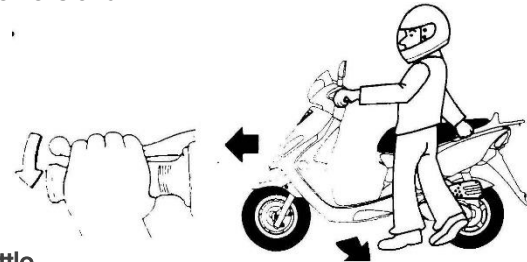

Throttle

Gradually turn the throttle to accelerate.

- A) Turning the throttle toward your body will increase your speed.
- B) Turning the throttle away from your body will decrease speed.

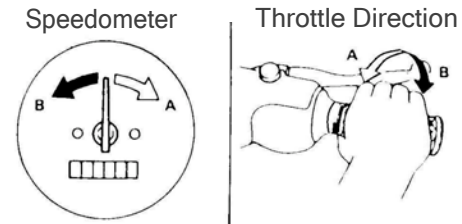

Operation



Braking

You should be prepared to use your brakes at all times. Unexpected behavior of fellow motorists, road debris, animals and other obstacles can arise without notice. Becoming familiar with and actively covering your brakes while riding can drastically reduce braking distances and improve safety.

Applying the brakes

1. Release the throttle
2. Gradually pull the brake lever(s) toward the handlebar to apply the brake.

Applying both brakes simultaneously will result in a shorter stopping distance than actuating either brake individually.

The right-hand brake lever actuates the front brake.

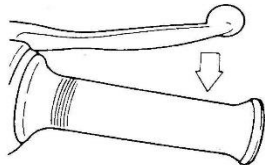

The left-hand brake lever actuates the rear brake.

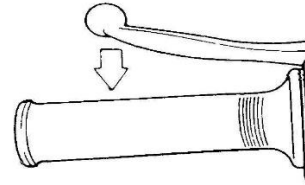

WARNING

Applying the brake lever abruptly or forcefully can cause the wheel to stop suddenly which can result in a loss of control of your vehicle. This effect is more prominent when the road surface is wet, covered in dirt or other debris, or you are traveling over metal objects. Always maintain acute awareness and full control of the braking force you are applying. Consider all environmental circumstances when braking.

Engine Stop

To stop the engine, turn ignition key to OFF. (3)
Remove the key.



It is not recommended to use the kill switch for normal engine stops. Leave the kill switch in the RUN position under all normal vehicle operation. Use the kill switch for emergency engine stops.

Parking

Park your vehicle with the exhaust facing away from any pedestrian traffic.

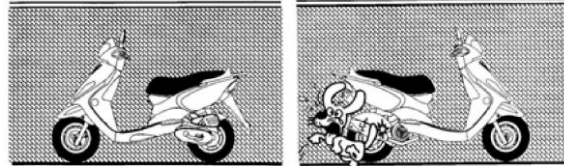

Correct

Incorrect

Place vehicle on the center stand whenever possible for the most stability.

If possible, park in front of larger vehicles so they can visibly see your parked vehicle.

Consider the firmness of the parking surface and any incline that may cause your vehicle to fall over.

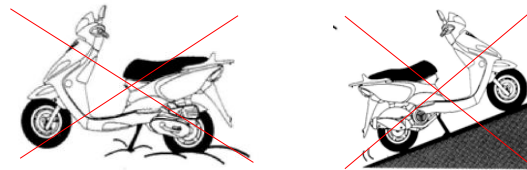

Periodic Maintenance



Periodic Maintenance and Repair

To ensure safe and effective performance of your vehicle, please check, adjust and lubricate your vehicle periodically. Safety should be every rider's priority and the maintenance table provided is an important guide.

Your vehicle is designed to be operated on normal paved surfaces. If you operate your vehicle in dusty, dirty and/or wet conditions, you will need to increase the maintenance frequency to account for the harsh operating conditions.

Failure to increase maintenance under harsh conditions will result in damage to the engine and other critical vehicle components.

If you are not technically skilled enough to perform any specific maintenance task, you should have the maintenance completed by an authorized Chicago Scooter Company dealer.

Periodic Maintenance Table

The following two pages contain a periodic maintenance table. Please review this thoroughly and follow all maintenance procedures as scheduled.

Once your vehicle exceeds the distances posted in the maintenance schedule, continue with the same periodic intervals for each item on the table.

Periodic Maintenance Key

- Inspect, then clean, adjust, or replace as necessary
- Mandatory replacement
- * Service should be performed by a Chicago Scooter

Company dealer

Periodic Maintenance Table



I = Inspection, cleaning, and adjustment R = Cleaning (replaced if necessary) S = Lubrication A = Replacement					
Component / Assembly	Before each trip	1st service after 1000 km	Every 3.000 km / 6 months	Every 6.000 km / 12 months	Every 12.000 km / 24 months
Air cleaner foam	I	I	R		A
Oil filter (screen)			R		
Engine oil	I	A	A		
Fuel filter	I	I	I		A
Spark plug	I	I	I		A
Ignition time		I	I		
Valve clearance		I		I	
Compression check			I		
Carburetor (Idle speed)	I	I	I		
Throttle cable adjustment	I	I	I		
Transmission oil	I	A	I	A	
Transmission check for leakage	I	I	I		
Crankcase check for leakage	I	I	I		
Crankcase ventilation		I	I		
Driving belt, flight weight			I	I / A	
Clutch discs			I	I / A	

Periodic Maintenance Table



I = Inspection, Cleaning, and Adjustment S = Lubrication		R = Cleaning (replaced if necessary) A = Replacement			
Component / Assembly	Before each trip	1st Service after 1000 km	Every 3.000 km / 6 Months	Every 6.000 km / 12 Months	Every 12.000 km / 24 Months
Bolts and Nuts (Engine)	I	I	I		
Compression Test			I		
Exhaust System		I	I		
Fuel Tank, Fuel Hoses	I	I	I		
Battery	I	I	I		
Steering and Bearings	I	I	I		
Front and Rear Suspension	I	I		I	
Shock Absorption	I	I		I	
Tire Pressure	I	I	I		
Brake Function, Brake Pads	I	I	I		
Brake Fluid	I	I	I		A
Center Stand and Side Stand	I	I	I / S		
Bolts and Nuts (chassis)	I	I	I		

Periodic Maintenance



Air Cleaner and Air Filter

- Remove screws from air cleaner cover. (1)
- Clean housing of dirt and debris with a clean cloth.
- Inspect gasket for integrity.
- Inspect air filter and replace if dirty or maintenance interval has been reached.
- Reinstall air filter and cleaner cover.
- Secure air cleaner screws.

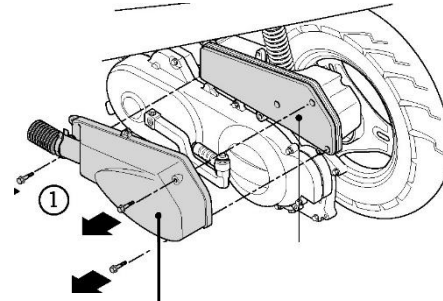

Gear Oil

- Change the gear oil per the maintenance schedule.
- Check level periodically (1) and inspect for leaks on the seals inside the transmission and on the output shaft near the rear wheel. If there is a leak, you will notice a build-up of oil and dirt. Resolve the leak immediately to prevent damage to the gearbox.
- Normal gear-oil change volume is 90cc
- Gear oil specification GL-4 85W-140

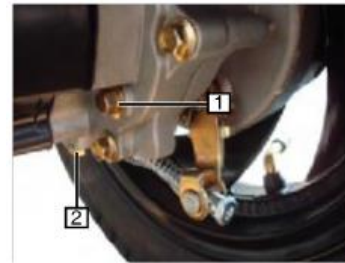

Transmission

- Check the transmission for belt and roller wear.
- Rollers should not have major flat spots.
- Measure belt width to determine wear.
- Inspect belt for cracks, frays or other damage.
- Inspect clutch pads for wear, glazing.

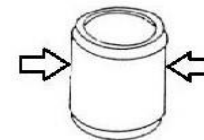
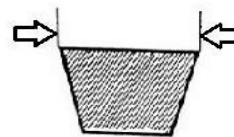

Periodic Maintenance



Spark Plug

The spark plug is one of the most important parts of the engine and it is easy to inspect.

The condition and color of your spark plug can provide important clues about the running condition of your engine. The ideal electrode color of a properly running vehicle is light brown. If the spark plug is white or black and wet, there may be a problem with your vehicle that needs to be resolved. Ask your Chicago Scooter Company dealer for assistance.

Standard spark plug: Torch A7RTC

- Inspect the spark plug electrode. Replace if you see damage or extreme wear to the electrode.
- Clean the surface of the spark plug gently to avoid damage.
- Measure spark plug gap.

Spark plug gap : 0.6 - 0.7mm

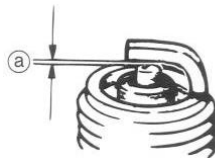

- Reinstall spark plug and torque.

Torque: 11.7 N-m (8 ft-lb)

Front Brake Check

Actuate the front brake for inspection. Observe the grooves in the pads. If the groove is gone or nearly gone, your brake pads need to be replaced.

- 1 Visually determine if the brake pads are worn to the bottom of the groove or measure the pad thickness.

If pad thickness is less than 2mm, replace the brake pads.

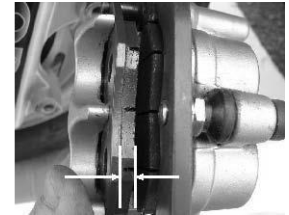

- 2 Visually inspect the brake rotor for scratches, warping, hot-spots, or foreign material. Any significant damage can indicate there is a problem with your brake system. Have your vehicle inspected immediately by an authorized Chicago Scooter Company dealer if any damage is observed.

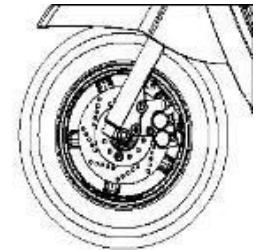

Periodic Maintenance



Brake Fluid Check

Insufficient brake fluid will allow air into the brake system and may cause the brake system to fail. Please check the brake fluid level regularly and refill it if necessary.

1. When checking the fluid level, please turn the handle bar to ensure the brake fluid indicator is horizontal.

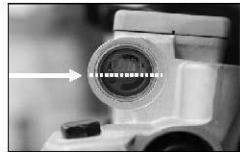

2. Only use specified brake fluid, otherwise the oil seals will deteriorate. Deterioration can cause fluid leaks & loss of brake function.

Standard brake oil: FMVSS DOT4.

 Caution: Do not mix brake fluid types.

3. Clean up any spilled brake fluid immediately with clean water. Brake fluid will erode painted surfaces and/or plastic.
4. If any problems are noticed with the fluid color, volume, leaking or any other problem with the brake system, have your Chicago Scooter Company dealer inspect immediately.

Suspension

Suspension is very important in vehicle stability. Malfunctioning suspension can cause your vehicle to behave in an unpredictable manner. Check regularly.

1. Check the inner surface of the front fork and rear shock for any wear, damage, or leakage.
2. Park the vehicle on a flat surface prior to inspection. Hold the handlebar and keep the vehicle in a vertical position. Apply the front brake.
 - Press and release the vehicle's front fork several times to check the front fork.



- Hold the rear grab-rail and press up and down several times to check the rear shock.

 **Caution**
If the suspension functions are not smooth or any component is damaged, immediately contact your authorized Chicago Scooter Company dealer for service.

Periodic Maintenance



Fuse Replacement

1. The main fuse is located next to the battery inside the floorboard section.
2. In the event of a broken fuse, disconnect the main switch and any switch connected to circuits that have failed. Install a new fuse corresponding to the correct Amperage. Turn on the switch to check the function. If the new fuse burns immediately, contact your authorized Chicago Scooter Company dealer for service.



Caution

Do not use fuses that are out of specification compared to the original fuse. Any fuse installed that is not to specification can seriously damage the electrical system.

Battery

1. It is unnecessary to add any electrolyte or distilled water into the sealed battery installed on the vehicle. In case of any sign of leakage of battery acid, immediately contact your authorized Chicago Scooter Company dealer.
2. If the engine has difficulty starting, weak horn, dim lights, etc., remove the battery from the vehicle and follow the standard procedure to charge the battery.

Battery Maintenance

A trickle/ maintenance charger is highly recommended if you do not use your vehicle on a daily basis. The battery will deplete over time if the vehicle is not run on a regular basis. Your Chicago Scooter Company dealer can recommend and install an appropriate charging device. You will be unable to start the vehicle with your electric start button if the battery has been depleted. Use the manual start option to start your vehicle.

Charge the vehicle's battery and fully disconnect the battery from the vehicle for long term storage such as winter. Store the battery in a warm location if possible. Charge the battery once every three months during this period.



Caution

Disassembling any sealed component on the battery can damage the battery. Never jump start the battery as this can damage vehicle electronics.

Periodic Maintenance Record



Maintenance Plan Mileage	Actual Mileage	Date	Dealer Signature	Maintenance Plan Mileage	Actual Mileage	Date	Dealer Signature

Technical Data



Engine		Chassis	
Type	LJ139QMB	Length	1690 mm / 66.5 in
Displacement	49.6cc	Width	645 mm / 25 in
Bore	39 mm	Height	1135 mm / 45 in
Stroke	41.5 mm	Wheelbase	1210 mm / 48 in
Compression Ratio	10.5:1	Curb Weight	78 kg / 172 lb
Cooling	Forced Air	Max Loading	108 kg / 238 lb
Lubrication Method	Separated Pump	GVWR	235 kg / 518 lb
Carburetor	You-All PD18J	GAWR - Front	67 kg / 148 lbs
Idle Speed	1600 ± 100 rpm	GAWR - Rear	168 kg / 370 lbs
Spark Plug	Torch A7RTC	Front Tire	3.5-10
Electrode Gap	0.6-0.7 mm	Rear Tire	3.5-10
Start System	Electric and Manual Kick-Start		
Transmission		Electrical	
Type	Continuously Variable (CVT)	Ignition System	CDI
Clutch	Dry, Centrifugal	Generator	Flywheel Magnet Stator
		Battery Type	12V 7Ah MF
		Main Fuse	15A Tube
Fluids			
Engine Oil Type	JASO MB 15W-40 Motor oil		
Engine Oil Capacity	~ 1.0 Liter		
Gear Oil Type	GL-4, 85W-140		
Gear Oil Capacity	150cc (130cc replacement volume)		
Fuel Type	Unleaded fuel, 87 Octane or higher		
Fuel Capacity	5.5 liters		

If you believe that your vehicle has a defect which could cause a crash or could cause injury or death, you should immediately inform the National Highway Traffic Safety Administration (NHTSA) in addition to notifying Chicago Scooter Company.

If NHTSA receives similar complaints, it may open an investigation, and if it finds that a safety defect exists in a group of vehicles, it may order a recall and remedy campaign.

However, NHTSA cannot become involved in individual problems between you, your dealer, or Chicago Scooter Company.

To contact NHTSA, you may either call the Vehicle Safety Hotline toll-free at 1-888-327-4236/Hearing Impaired (TTY): 1-800-424-9393; or write to Administrator, NHTSA, 1200 New Jersey Avenue, SE, Washington, DC 20590

WARRANTY INFORMATION

Your vehicle is covered by a manufacturer's limited warranty, and an EPA emissions related components warranty.

Detailed warranty information can be found in your warranty booklet.

This owner's manual should always remain in your vehicle for reference. This manual should be considered a permanent part of your vehicle. The information contained within this manual is the latest available at the time of publication. Chicago Scooter Company reserves the right to make changes to products and publications at any time without notice. There may be information in this manual that differs slightly from your vehicle as improvements and changes occur regularly.



www.chicagoscootercompany.com
info@chicagoscootercompany.com

